

THE POWER OF TOMORROW. TODAY.



Velox i
Ultra Rapid EV Charger (EVC)
Customer Manual

CM1-1



IMPORTANT

PLEASE READ ALL INSTRUCTIONS CAREFULLY BEFORE USE

KEEP SAFE FOR FUTURE REFERENCE

The contents of this Customer Manual are subject to recurring updates and modifications, as the Velox / Ultra Rapid EVC undergoes regular reviews for improvements.

Before any use, please check and download the latest revision of the Customer Manual using the QR code or hyperlink below to stay informed about any future changes.



OR

[CM1-1 Velox / Ultra Rapid EV Charger Manual](https://www.turbopowersystems.com/ev-charging-velox-stand-alone-manual/)

(<https://www.turbopowersystems.com/ev-charging-velox-stand-alone-manual/>)

PLEASE NOTE: This document is intended for the following groups:

- The **OWNER** of the EVC
- **USERS** of the EVC including but not restricted to Installation and Maintenance personnel.

Responsibilities for the OWNER

It is the responsibility of the OWNER to ensure all USERS are able to install, maintain and operate the EVC in a safe manner.

For the purposes of this manual the OWNER is defined as:

The person, people or entity which holds legal title in the EVC. The OWNER is also a USER.

For the purposes of this manual a USER is defined as:

Anybody who comes into contact with the EVC for any purpose after the point of delivery to the OWNER. This includes but is not restricted to:

- Transportation and storage of the EVC
- Installation of the EVC
- Maintenance and inspection of the EVC
- Operation of the EVC for the purpose which it is intended.

Discharging the OWNER'S responsibilities includes but is not restricted to:

- Ensuring the instructions in this manual are understood and followed at all times.
- Ensuring installation of the EVC is carried out by appropriately qualified personnel.
- Ensuring all maintenance and inspection of the EVC is carried out by appropriately qualified personnel.
- Ensuring this document is kept in a safe location where it is easily accessible. It is an essential part of the EVC system.

Copyright

All rights to copyrights, registered trademarks, and trademarks reside with their respective owners.

Copyright © (2024) All rights reserved. The information contained in this document is proprietary to Turbo Power Systems Limited ("TPS"). By accepting this document, the recipient agrees to protect its contents from further dissemination. The recipient may within its organisation use such information only as is permitted for the necessary evaluation of the information. Any other use is prohibited (including anything that would create independent economic significance) without the express written permission of TPS.

Contents

1. GENERAL INFORMATION	5
1.1. PRODUCT SUPPORT CONTACT INFORMATION	5
1.2. LANGUAGE	5
1.3. ACRONYMS AND ABBREVIATIONS	6
1.4. FIGURES	6
2. SAFETY	7
2.1. SAFE WORKING PRACTICES	7
2.2. PRECAUTIONARY NOTICES	7
2.3. SAFETY PRECAUTIONS TO CONSIDER WHEN WORKING ON THE VELOX / ULTRA RAPID EVC	8
2.4. DISCLAIMER	8
2.5. WARRANTY	9
3. PRODUCT INFORMATION	10
3.1. FUNCTIONALITY	10
3.2. TECHNICAL OVERVIEW	11
3.3. TECHNICAL DATA	12
3.4. GENERAL ARRANGEMENT OF VELOX / ULTRA RAPID EVC	13
3.5. STORAGE	14
3.5.1. GENERAL STORAGE	14
3.5.2. LONGER TERM STORAGE	14
3.6. PACKAGING	14
4. INSTALLATION	15
4.1. TOOLS REQUIRED TO INSTALL THE VELOX / ULTRA RAPID EVC	15
4.2. MECHANICAL INSTALLATION OF THE VELOX / ULTRA RAPID EVC	15
4.2.1. VELOX / ULTRA RAPID EVC CLEARANCE ZONE AND DISTANCE TO THE POTENZA DGI	16
4.3. UNPACKING THE VELOX / ULTRA RAPID EVC	17
4.4. LIFTING AND POSITIONING THE VELOX / ULTRA RAPID EVC	18
4.5. ELECTRICAL INSTALLATION OF THE VELOX / ULTRA RAPID EVC	21
4.5.1. CABLE ENTRY POINTS	21
4.5.2. TERMINATION DETAILS	22
4.5.3. CONNECTION OF DC CABLES FROM THE POTENZA DGI OR OTHER DC SOURCE	22
4.5.4. CONNECTION OF AC CABLES (AUXILIARY POWER)	23
4.5.5. CONNECTION OF EARTH (PE)	23
4.6. SAFETY PRECAUTIONS DURING INSTALLATION, OPERATION AND MAINTENANCE	24
4.6.1. CONNECTION OF COMMUNICATIONS (E.G. ETHERNET)	25
4.6.2. CONNECTION OF CABLES TO HMI SCREEN, PAYMENT DEVICE AND PE STUD	26
5. COMMISSIONING	28
6. VELOX / ULTRA RAPID EVC OPERATION	29
7. PREVENTATIVE MAINTENANCE AND INSPECTION INFORMATION	31
7.1. CABLES, CONNECTORS & HOLSTERS	32
7.2. CLEANING THE EXTERIOR OF THE VELOX / ULTRA RAPID EVC	32
7.3. AIR DUCTS AND VENTS	33
7.4. ENCLOSURE AND HATCHES	33
7.5. LEDS	33
7.6. HMI	34
7.7. PAYMENT DEVICE / RFID	34
7.8. ISOLATION SWITCHES	34
8. TROUBLE SHOOTING	35
8.1. FAULT CODES AND ACTIONS	35
8.2. PERFORMING A HARD RESET OR FULL POWER CYCLE	35
9. END OF LIFE DISPOSAL OF THE VELOX / ULTRA RAPID EVC OR COMPONENT PARTS	36
10. DOCUMENT HISTORY	36
11. APPENDIX A – VELOX / ULTRA RAPID EVC – OUTLINE DRAWING	37
12. APPENDIX B – INSTALLATION CHECKLIST DOCUMENT	39
13. APPENDIX C – MAINTENANCE & INSPECTION RECORD	40
14. APPENDIX D – PACKING	41
15. APPENDIX E – VELOX / ULTRA RAPID EVC – FOUNDATION PROPOSAL	42
16. APPENDIX F – VELOX / ULTRA RAPID EVC REINFORCED CONCRETE BASE	43

1. General Information

Turbo Power Systems Limited (TPS) operates an integrated Business Management System which includes Health & Safety, Environmental & Quality Management. TPS complies with ISO 45001:2018, ISO 9001: 2015 and ISO / TS 22163:2017.

1.1. Product Support Contact Information

Turbo Power Systems - UK Headquarters

1 Queen's Park
Queensway North
Team Valley Trading Estate
NE11 0QD
United Kingdom

 +44 (0) 191 482 9200

 info@turbopowersystems.com

Turbo Power Systems - USA Office

 +1 (404) 422 5905

 gridley@turbopowersystems.com

Turbo Power Systems - Brazil Office

 +55 (21) 96888 2260

 ahenriques@turbopowersystems.com

You can contact the Turbo Power Systems Customer Support Team via the following means:

 customersupport@turbopowersystems.com

 +44 (0) 191 482 9227

 +44 780 9656 709

 Monday to Friday (excluding bank holidays): 08:00 to 21:00 GMT*

*Additional support may be available outside these hours. For further details, please refer to your contract / service level agreement.

 www.turbopowersystems.com

Before contacting TPS, please ensure you have the serial number of your Velox / Ultra Rapid EVC to hand. Details of where to find the serial number are in section 3.4 of this manual. The serial number must be quoted in all communications with TPS.

1.2. Language

The original language of the document is English. All other language versions are translations of the original instructions.

1.3. Acronyms and Abbreviations

AC	Alternating Current
CHAdeMO	Charge de Move
CCS	Combined Charging System
DC	Direct Current
DC-DC	DC-DC converter
DGI	Distribution Grid Inverter
EV	Electric Vehicle
EVC	Electric Vehicle Charger- in this manual the Velox / Ultra Rapid EVC
HMI	Human Machine Interface
kW	Kilowatt
LH	Left Hand
OWNER	The Person who retains the title of the goods
OCPP	Open Charge Point Protocol
PCB	Printed Circuit Board
PE	Protective Earth
RH	Right Hand
SiC	Silicon Carbide
SWL	Safe Working Load
TPS	Turbo Power Systems
USER	The person who uses the equipment for its intended purpose of charging or discharging an EV
V2G	Vehicle to Grid
V2X	Vehicle to Everything

1.4. Figures





It is not always possible or practical to show the exact configuration of your Velox / Ultra Rapid EVC. Any figures used within this document are indicative and are for instruction and description purposes only.

2. Safety

2.1. Safe Working Practices

<h1>WARNING</h1>	
	1. Only suitably trained and authorised personnel should be allowed to work on this EVC.
	2. This EVC uses high voltage: all possible steps must be taken to maintain safety of the personnel and any staff working near the EVC at all times.
	3. Once the installation is completed, under no circumstance should the covers be removed unless undertaken by either Turbo Power Systems or an approved / trained person.

2.2. Precautionary Notices

	WARNING! RISK OF ELECTROCUTION	Indicates an operation, sequence, or function that, if not observed, may cause electrocution or death to personnel and/or serious damage to equipment. Strictly adhere to all warnings.
	WARNING! RISK OF INJURY	Indicates an operation, sequence, or function that, if not observed, may cause serious injury or death to personnel and/or serious damage to equipment. Strictly adhere to all warnings.
	CAUTION! RISK OF DAMAGE TO EQUIPMENT	Indicates an operation, sequence, or function that, if not observed, may cause damage or malfunction of equipment.
	ATTENTION! OBSERVE PRECAUTIONS FOR HANDLING	This unit contains Electrostatic Sensitive Devices (ESD). DO NOT TOUCH any electrical components without Anti-Static Precautions.
	NOTE	Provides additional explanatory information that may not be readily apparent from the text or illustrations.

2.3. Safety Precautions to consider when working on the Velox / Ultra Rapid EVC

This section contains a list of general safety precautions. Before attempting any work, read and understand these precautions. Failure to do so can result in death or serious injury to individuals or damage to equipment. If in doubt regarding any of these precautions, ask for an explanation from your immediate supervisor before proceeding with any installation or maintenance task.

WARNING:

- High Risk of electrocution in this EVC if covers are removed.
- 800V DC and 240V AC are present within this EVC when it is not isolated.
- Should the covers need to be removed by either Turbo Power Systems or an approved / trained person all supplies must be isolated and a minimum of 5 minutes be allowed for the EVC to discharge.



2.4. Disclaimer

The manufacturer (Turbo Power Systems) is not liable for any damages, losses, costs, expenses, or injuries incurred by any USER of the Velox / Ultra Rapid EVC, if such damages, losses, costs, expenses, or injuries occur as a result of failure to comply with all the instructions contained in this manual. This includes but is not limited to the following:

- Any damage or injury caused as a result of power outages or disruptions to the electrical supply to the EVC.
- Any damage resulting from accumulation of dirt or ingress of foreign substances within the EVC.
- Any damage resulting from corrosion of component parts.
- Any damage resulting from unauthorised upgrades, enhancements or modifications to the equipment or its use.
- Any damage to the software or hardware due to an IT security problem (i.e. virus breakout, malicious hacking of the system, etc.)
- Any damage or failure caused by vermin, insect infestations or the like.
- Any damage or failure resulting from faults in some other equipment connected to the scope of work.
- Any damage, injury or loss caused by hazards such as fire, flood, storm or the like, spillage or leakage of chemicals or harmful substances into the EVC.
- Any damage resulting from an external source, unprofessional, incorrect, or non-compliant installation,
- Any damage, injury or loss resulting from improper operation, negligence or unauthorised repairs by third parties.
- Any damage or injury caused by failure to comply with all safety instructions or legal standards by users of the equipment.
- Any damage caused by insufficient ventilation of the EVC.
- Any damage resulting from operation of the EVC outside of its design conditions.



2.5. Warranty

As per the Supply of Goods and Services agreement between Turbo Power Systems and the OWNER, the goods supplied, and all products supplied shall:

- Conform to the configuration specified and technical data, contained within section 3.3.
- Be of satisfactory quality and fit for any functionality and purpose set out in the configuration specified and technical data, contained within section 3.3.
- Be free from defects in design, material and workmanship and remain so for the contract specified period after delivery to the OWNER.

3. Product Information

3.1. Functionality

The Turbo Power Systems Velox / Ultra Rapid EVC is an innovative DC supplied Electric Vehicle Charger designed for connection to a DC supply, ideally a DC microgrid.

The Velox / Ultra Rapid EVC has been designed and tested in accordance with international standards IEC 61851 (DC Charging) and IEC 62196 (Plugs).

A DC microgrid enables EV Charger load management to ensure capacity is not exceeded, whilst creating additional capacity locally through the connection to it of on-site energy storage and generation. The DC connection also gives geographical flexibility by enabling the network to span larger distances.

The charging control module located within the Velox / Ultra Rapid EVC, interfaces with the back-office systems of the Charge Point Operator, other vehicles and other EV charging subsystems to allow compatible vehicles to be charged. The EVCs, which connect to the DC microgrid contain a bi-directional DC-DC converter which both controls the charge to the EV and enables V2G/V2X vehicle discharging capability.

On-site battery storage and generation, for example solar PV, are connected to the DC microgrid via their own DC-DC conversion stages (Maximum Power Point Tracking included for solar PV). This allows for minimal power transfer to occur directly between the vehicle and grid. The Energy Management System controls power transfers between all connected elements and ensures charging power is drawn from the battery storage and/or solar energy at times of peak grid electricity tariff in preference to the grid.

Where grid capacity alone is sufficient for EV charging needs, Velox / Ultra Rapid EVCs can be used with a TPS Potenza LV Distribution Grid Inverter to simply provide a 'hub and spoke' charging system, with V2G / V2X capability,

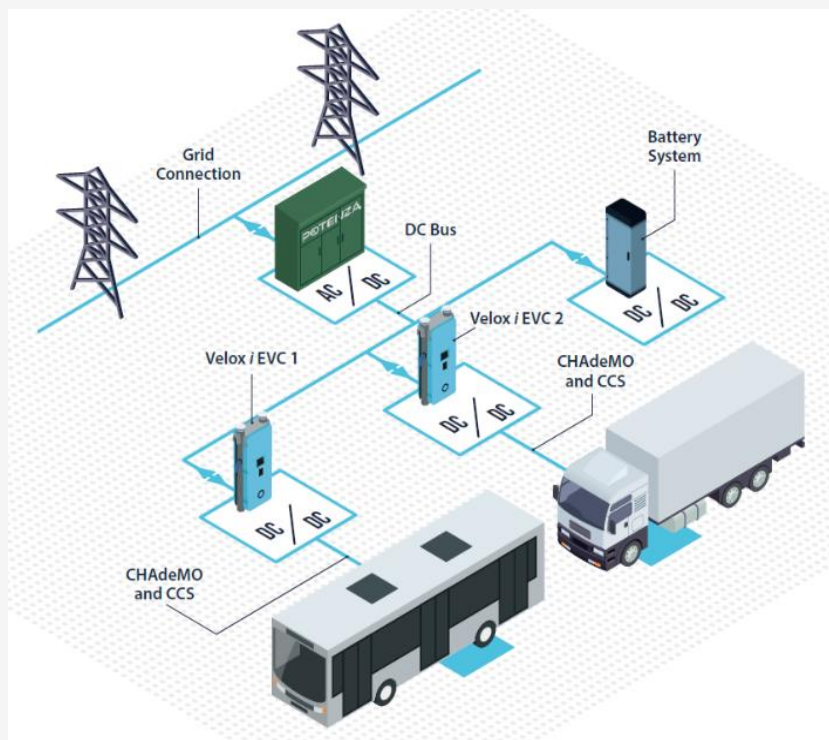

Figure 1 - A typical Velox / Ultra Rapid charging system arrangement

PLEASE NOTE: The Velox i Ultra Rapid EVC is primarily intended for use with TPS own Potenza LV Distribution Grid Inverter (DGI). If the application for which the EVC is intended requires its use with a non-TPS supplied DC interface unit, please contact TPS to discuss the details of this application, as variations to the contents of this manual may apply, and there may be an impact on the Warranty terms and conditions.

3.2. Technical Overview

The Velox i Ultra Rapid EVC uses SiC semiconductor devices that have very low losses at high frequency. High frequency operation results in low audible noise with reduction in magnetics component size and weight. The DC-DC is designed to be able to import or export power from the vehicle battery (enabling V2G charging and/or V2X operation). As a result, the EVC can perform the following functions:

- Ultra rapid charging
- Bi-directional power transfer
- High efficiency flows
- Near silent operation
- CCS and CHAdeMO charging profiles.

The Velox i Ultra Rapid EVC contains the power module along with supporting components and provides the mounting for the CHAdeMO and CCS charge cables. The power electronics components are force air cooled with high reliability fans.

All high-power hardware is protected through internal contactors, fuses, breakers and software trips on the input and output stages of the EVC.

All charges are monitored through an insulation monitor PCB which measures and reports the resistance of the CHAdeMO/CCS cables before performing a charge to ensure the charging cable is safe to operate.

The user interface is provided by an HMI. Instructions are clearly displayed on the user interface for a simple and reliable user experience. The HMI will display active real time charging data during a charge such as state of charge, power transferred (kWh), time and cost where appropriate.



Figure 2 - Velox i Ultra Rapid EV Charger

3.3. Technical Data

Model	Velox / Ultra Rapid EV Charger
Max Rated output power	120 kW @ >600 V vehicle battery
Max charge current	200A
DC Supply voltage	775-825 VDC, with <5% ripple
Nominal DC supply current	160 A
AC Supply voltage	Nominal 230 (+10% -6%) Vac 1P, 50/60 Hz
Nominal AC Supply current	13 A
Isolation	Galvanically Isolated
Electrical Protections	Main contactor disconnection
Vehicle battery voltage range	150-920 Vdc
Efficiency	>98%
Connectors / Charging protocols	CCS1/2 and / or CHAdeMO with single port operation
Status indication	LED charging indicators
RFID system	ISO / IEC14443-1/2/3 MIFARE Classic
Network connection	GSM/3G/4G modem; 10/100 Base-T Ethernet
Communication Protocol (backend)	OCPP v 1.6 / 4G
Communication Protocol (EV)	ISO15118, DIN 70121
Operating temperature	-20 to +50 °C
Storage temperature	0 to +20 °C
Protection / IP RATING	Power electronics/control area IP56, Rear ventilated area IP22 (containing IP56 fan)
Operating Altitude	Max 1000 m without derating
Cooling	Air
Operating Humidity	<95%
Storage Humidity	<95%
Operational noise level	<56 dBA @ 5.0m
Charge cable Length	4.5 m as standard
Dimensions (H x W x D)	1820 (h) x 1070 (w) x 630 (d)
Weight	370 kg
Compliance and safety	Designed for compliance with IECC 61851-23
Optional Items	<ul style="list-style-type: none"> • V2X capable (charge / discharge) • LED charging indicators • Internet Connections (Wired / Wireless) • Cable Lengths • Payment System / RFID

3.4. General Arrangement of Velox i Ultra Rapid EVC



Figure 3 - Velox i EVC Front and right-side views



Figure 4 - Velox i EVC Rear and left-side views

PLEASE NOTE: The rating plate is located on left-side face. Always quote the unit serial number when contacting the TPS Product Support Team.

1 Queens Park,
Queensway North,
Team Valley Trading Estate
Gateshead, Tyne and Wear,
NE11 0QD
Phone:- +44(0)191 482 9200
www.turbopowersystems.com

TURBO POWER SYSTEMS

EV Charger		Manufacturing Date (MM/YYYY)	
TPS Part No.		Serial No.	
DC Connection Voltage	800VDC	CHAdemo	125A Max.
AC Connection Voltage	230VAC, 50Hz	Weight (Kgs)	450
Continuous Rating	120kW	CCS	200A Max.
Input Current	135A	Dimensions	1800H x 800W x 600D
DC Output Voltage	150-820V		

MOD RECORD	1	2	3	4	5	6	7	8	9	10	11	12	13	14	15	16	17	18	19	20
------------	---	---	---	---	---	---	---	---	---	----	----	----	----	----	----	----	----	----	----	----

3.5. Storage

3.5.1. General Storage

- The Velox / Ultra Rapid EVC must be transported and stored in its original packaging. TPS is not liable for any damage incurred when the EVC is stored or transported in non-TPS packaging.
- It must be stored out of direct sunlight in a dry environment.
- Always disconnect the input power before removing the EVC for storage or transport.
- Always transport the EVC in the upright position.
- Always lift the EVC crate from the base using a suitable forklift truck.

3.5.2. Longer Term Storage

If the Velox / Ultra Rapid EVC is switched off for a period exceeding 6 months, an inspection will be needed before it can be switched back on. This must be carried out by TPS or an approved / trained person. Please contact your TPS Product Support Team, details are provided in section 1.1.

3.6. Packaging

The EVC is fixed onto wooden transport feet, which are locked onto a pallet. The EVC is encapsulated with a foil bag to prevent moisture ingress, before being enclosed by a bespoke wooden crate. This crate must be kept upright at all times. Care must be taken when removing the crate to avoid damage to the EVC.

The approximate dimensions and weight of the packaged EVC are below:

Height	2,130 mm / 83.9 inches
Width	1,380 mm / 54.4 inches
Depth	960 mm / 37.8 inches
Weight	520 kg / 1,147 lbs with packing crate

4. Installation

PLEASE NOTE: The Velox / Ultra Rapid EVC must only be installed by Turbo Power Systems or a qualified Installation Engineer.

The qualified Installation Engineer must:

- Have a full working knowledge of the EVC and its safe installation.
- Be qualified according to the applicable local rules to do the work e.g. in the UK, BS 7671 18th Edition, in the USA, NFPA 70, National Electrical Code (NEC)
- Comply with the instructions contained in this manual.

4.1. Tools required to install the Velox / Ultra Rapid EVC

This is a non-exhaustive quick reference list of the essential tools required to carry out the key elements of the installation:

- 24mm spanner and socket for the transport fixings on the base.
- 22mm socket for SW1 isolator.
- T30 security Torx bit or driver for all external fixings on covers and LED's.
- Terminal screwdriver to enable the AC connections.
- 17mm socket for attachment of the DC in conductors.
- 10mm spanner and socket for the attachment of the PE conductors.
- Torque wrench, range 4.5-30 Nm.
- Tools to cut and strip electrical cables.
- Crimping tool to suit any electrical crimps that are used to terminate cables.

4.2. Mechanical Installation of the Velox / Ultra Rapid EVC

This section contains information relating to the siting, unpacking and fixing of the EVC into its designated location.

For dimensions relevant to the mechanical installation of the EVC, please refer to Appendix A – Velox / Ultra Rapid EVC – Outline Drawing, which includes a link to the latest version.

PLEASE NOTE: TPS recommends using an EV Charger Power Charge Foundation manufactured by NAL Ltd (Drawing No: 9000-1027, TPS Part Number: 170061) within the installation. A drawing is available in Appendix E – Velox / Ultra Rapid EVC – Foundation Proposal and TPS advises that the OWNER work with NAL directly to ensure the foundation is optimal for purpose and installed correctly.

If a non-NAL solution is to be used, TPS recommends that the OWNER follows the Design Requirements and Performance Specification (TPS Document Number: 325-067) a link to which is available in Appendix F – Velox / Ultra Rapid EVC Reinforced Concrete Base. This must be accepted as a minimum requirement within the installation and responsibility for its accurate interpretation and proper implementation rests solely with the OWNER.

4.2.1. Velox / Ultra Rapid EVC clearance zone and distance to the Potenza DGI

Within a TPS system, the total cable length between the Potenza LV DGI and Velox / Ultra Rapid EVC must not exceed 100 metres.

If installation is to be in a closed building, the room in which the Potenza LV DGI and Velox / Ultra Rapid EVC will be located must have a system of permanent renewal of air.

Recommended free space for ventilation and maintenance is shown below:



Figure 5 - Clearance Zone

4.3. Unpacking the Velox / Ultra Rapid EVC



Before beginning the unpacking process, please check the transport indicators as instructed in the Velox / Ultra Rapid EVC Quick Guide CM2-1, which accompanies the EVC. There are 2 types of indicators fitted; one to record shock, the other to record tilt. If either of these has been triggered, they will show a **RED** signal.



Figure 6 – Packing Crate & Indicators

If either indicator is showing a red signal, a record of this must be made on the delivery paperwork. Next, Inspect the packaging fully. If there is any visible damage, pause the unpacking process until the carrier can attend to make a full inspection and witness the rest of the unpacking process.



Figure 7 - Packed Unit

The packing crate is shown above. To help with removal, the main screws are circled with a **RED** marker pen as shown. For details of the construction of the packing crate, please refer to Appendix D – Packing. Disassembly is the opposite of assembly. The protective foil bag surrounding the EVC is sealed during packing to protect it from moisture. This should still be intact. Carefully cut the foil bag open and remove it. Locate the box containing the LEDs (shown in the packing instruction) and remove it for safe keeping. Locate and remove the 2 off charging cables and place them in their holsters.

If after unpacking, the EVC is found to be damaged in any way, **STOP** immediately. Inform the **OWNER** of the EVC and **TPS** urgently, taking and sharing photographs to indicate the areas of this damage. See section 1.1 for **TPS** contact details. **YOU** will be informed of the next steps.

If there is no visible damage, proceed as below.

4.4. Lifting and Positioning the Velox / Ultra Rapid EVC



The EVC must be lifted from its transport base with appropriate equipment suitable for a SWL of 400 kg / 900 lbs. Two lifting eyes with M16 male thread of appropriate SWL will be required. It is the responsibility of the **OWNER** to ensure that all lifting and handling operations are carried out in a safe manner and are compliant with any local regulations.

Please refer to the following steps for information on lifting the EVC. Please pay particular attention to any Health and Safety requirements which may apply (e.g. working at height, selection and use of appropriate lifting equipment, use of appropriate PPE etc).

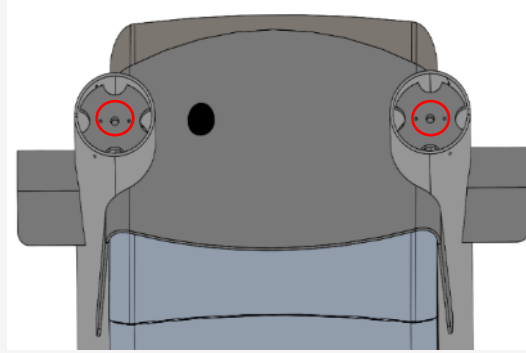

Figure 8 - Top view for Lifting eyes

Step 1: Screw the lifting eyes into the M16 threaded holes. The eyes must screw in fully.

Step 2: The EVC can now be lifted and moved into position. Before lowering, the wooden transport feet will have to be removed using a 24mm spanner and socket to undo the 4 off securing nuts and bolts. Details of the position of the bolts can be found in Appendix D – Packing section 3.5. When lowering the EVC onto its foundation, care must be taken to ensure the incoming cables are located appropriately for the glanding (see section 4.5.1 for details).

Step 3: Fix the EVC directly to its concrete foundation using recommended fixings. You will find the details of these in Appendix F – Velox i Ultra Rapid EVC Reinforced Concrete Base, point 6.

Step 4: Align the EVC, tightening all fixings to recommended torques.

Step 5: Remove lifting eyes and fit the LED lighting. The LEDs fit on top of the EVC frame towers as shown in section 7.5.

Step 6: Before fitting, check the LEDs are not damaged and that the mounting hardware (which is included in the box with the LEDs) is present and undamaged. Remove the hardware from the LED.



Figure 9 - LED's

Step 7: Feed each LED's power cable through to the inside of the EVC. The cable and plug from the LED are shown below on the left. They need to be connected to the socket which is part of the control harness inside the EVC which is shown on the right. The connector will be found in the upper RH and LH corners of the unit. RH is LED 6 shown, LH is LED 5. This can only be carried out when the front cover has been removed. See section 4.5.2 for details.



Figure 10 - LED connectors

Step 8: Then lower the LEDs into position on top of the towers and secure in position using the 3 fixings provided. (M6x16 T30 security screws and flat washers). There is no tightening torque for these. They should be a snug hand tight to prevent damage to the LED housing. LED 6 is on the RH post, LED 5 is on the LH post.



Figure 11 - LED on Tower

4.5. Electrical Installation of the Velox / Ultra Rapid EVC



The information provided in this section is for guidance only. For the latest details on electrical installation please refer to 'Unit Outline', shown in Appendix A – Velox / Ultra Rapid EVC – Outline Drawing, which includes a link to the latest version.

4.5.1. Cable Entry Points

DC, PE (Protective Earth), AC and Comms interface.

DC, AC and comms termination points and the PE terminal are located inside the EVC enclosure at the base of the EVC.

Input cables enter the enclosure through the base of the EVC. The EVC design has allowed for a suitable cable bend radius.

CABLE ENTRY POINTS

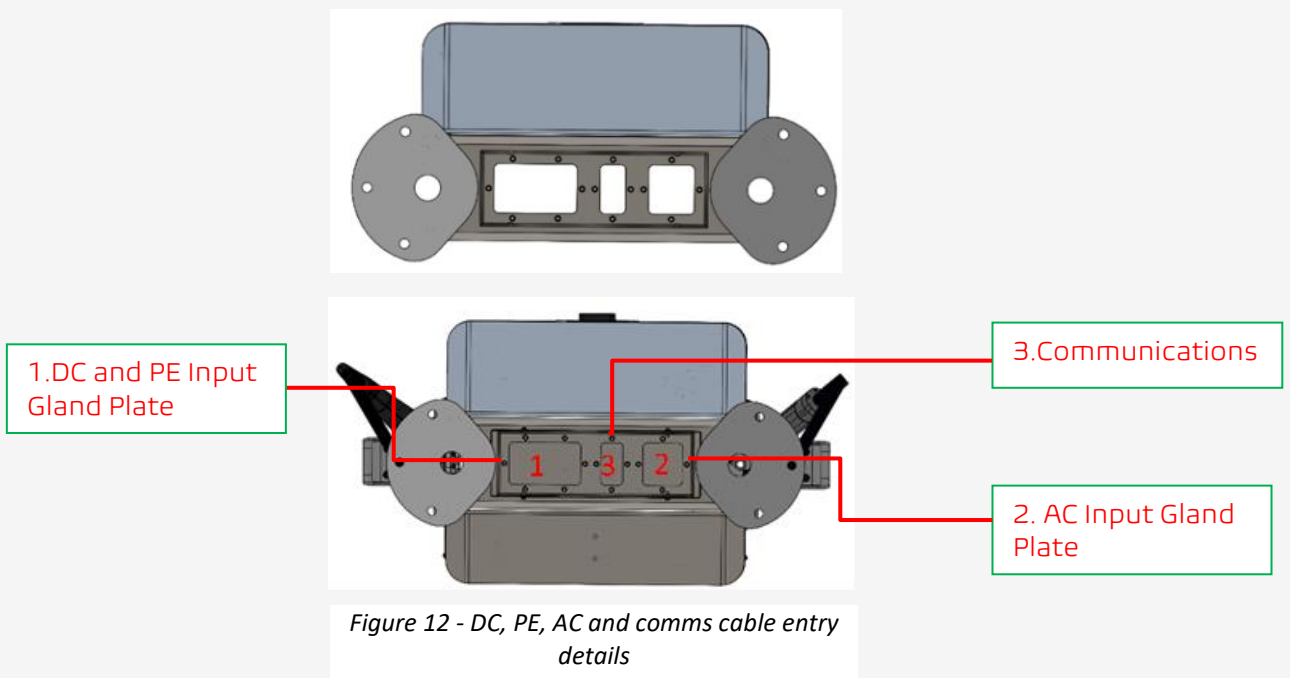

PLEASE NOTE: Gland plates are undrilled to allow installation using different cable sizes. IP65 glands are recommended. Make sure that all gland plate PE cables are re-fitted if they have been removed for gland hole drilling.

Health and Safety guidance must be followed when drilling holes for the cable glands.

4.5.2. Termination Details

To make the internal electrical connections, the front cover of the Velox *i* Ultra Rapid EVC needs to be removed. **THIS IS THE ONLY INSTANCE WHERE A COVER SHOULD BE REMOVED.** Before doing this, it is important to ensure that any isolation devices inside the maintenance hatch are in the **OFF** position. See section 8.2.

To take off the front cover, the 6 off M6x16 T30 security fixings will need to be removed. For location see Figure 13 - Cover Removal below. Then the front cover must be carefully eased forward by **no more than** a maximum of 150-200mm to allow a check to be made that the PE and the internal cables for the HMI and Payment Module or RFID units (if fitted) have been disconnected from the cover. Once the check has been made, the cover can be lifted clear.

All incoming power cables must be cut to the required length and terminated in an approved manner (in the UK this would be BS 7671 18th Edition) using the correct tooling. Use the following information as a guide, and a reference to the required fixing torques.



Figure 13 - Cover Removal

4.5.3. Connection of DC cables from the Potenza DGI or other DC source

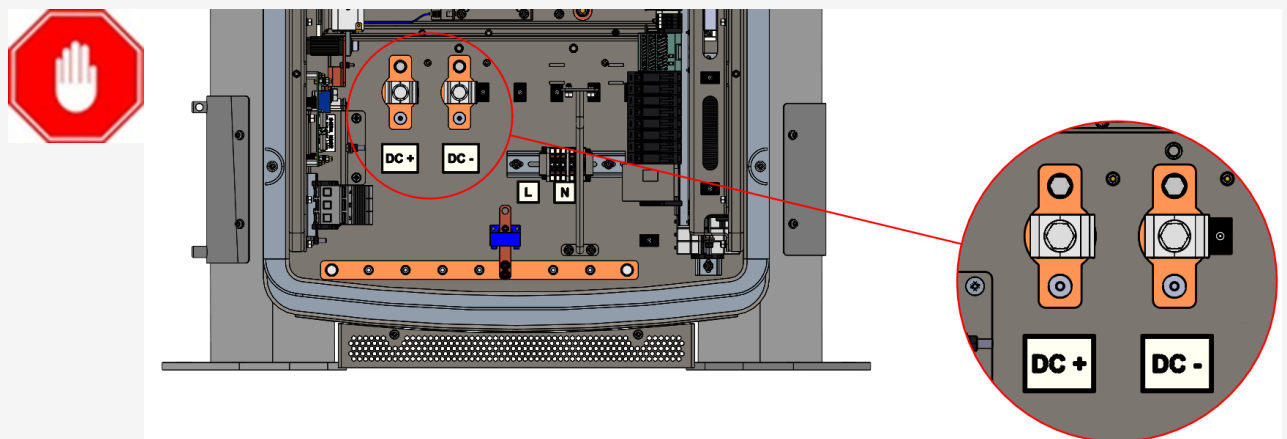

Figure 14 - DC input terminal connection details

Both DC terminations are made using the same type of connector. A 17mm socket is required. **PLEASE NOTE** : This connector employs a 'shear bolt' fixing. The head of the fixing will shear off at a pre-determined torque. The connector therefore, is a 'single use' design.

4.5.4. Connection of AC Cables (Auxiliary power)

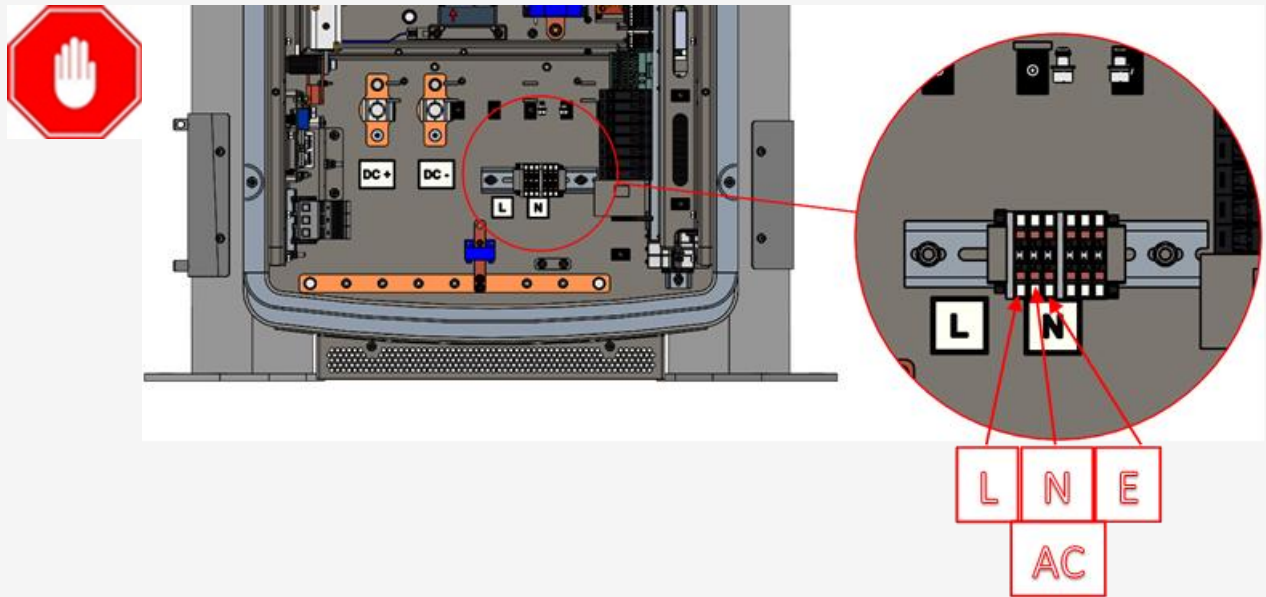

Figure 15 - 230 VAC Live (L), Neutral (N) and Earth (E) can take cable up to 2.5 mm²

The 230 VAC 1P cables are terminated into standard 'Wago' push-in connectors. Cables should be terminated with an appropriately sized bootlace ferrule before being inserted.

4.5.5. Connection of Earth (PE)

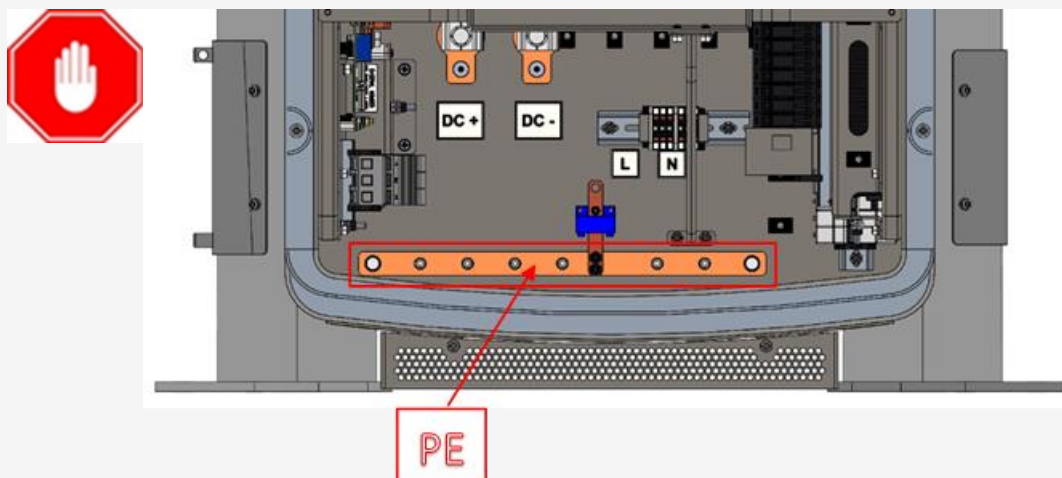

Figure 16 - Earth (PE) terminals can take cable with M8 termination, 6Nm torque

The PE cables are connected to the PE busbar with M8 fixings. The cables need to be terminated with an appropriate M8 lug fixing and heat shrink.

4.6. Safety Precautions during Installation, Operation and Maintenance

- Attention must be paid to all precautionary notices explained in this section.
- Do not attempt to operate the EVC if there is visible damage, or the unit is displaying a fault.
- Please report any faults and or damage to the EVC immediately to the OWNER.
- Never apply power to the EVC without the covers in place.
- Always use the EVC as described.
- Ensure that the EVC charging connectors are correctly placed in the holsters provided when not being used, and that the charging cables are not twisted or tangled.
- Ensure that the EVC charging connectors cannot be immersed in any liquid.
- The EVC must be installed to allow access and good ventilation, especially to the rear of the unit.
- Do not place any objects which could block the rear vents. See section 4.2 of this manual for required clearances for ventilation and access.
- Do not install the EVC close to any heat sources.
- If in doubt refer to the installation drawing shown in Appendix A – Velox / Ultra Rapid EVC – Outline Drawing, with the link to the latest version, which will contain the latest information.

REPORT ANY PROBLEMS, ISSUES AND CONCERNS IMMEDIATELY TO THE OWNER AND TPS

4.6.1. Connection of Communications (e.g. Ethernet)

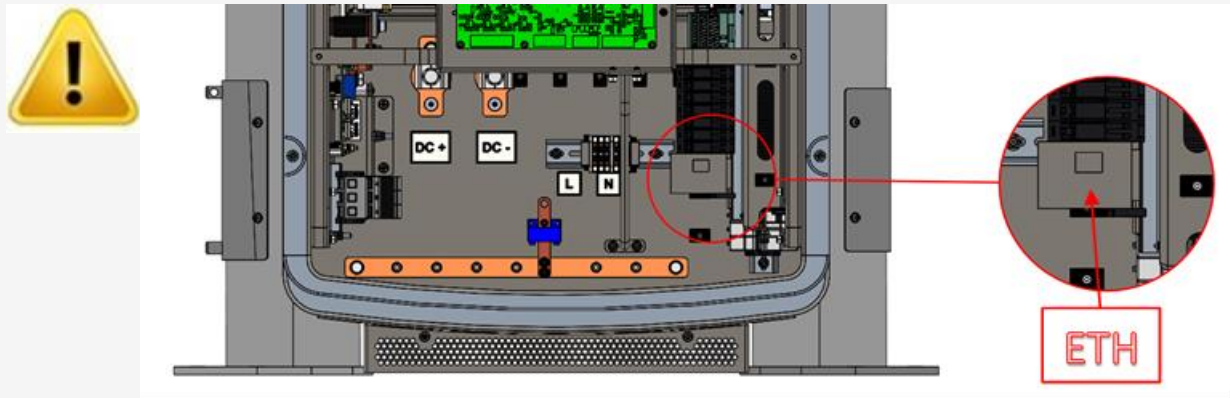

Figure 17 - The ethernet switch uses a standard RJ45 cables (spare ports are provided)

Subject to specification, there may be a requirement for a communications cable such as Ethernet to be included. This should be routed through a gland and terminated with a suitable connector.

When all cable connections have been made and verified, including the LED's, the front cover can be refitted.

When refitting the front cover, ensure that all seals are in good condition and correctly positioned. The cables for the HMI and any payment or RFID devices will have to be connected, along with the PE cable. See section 4.6.2 for details on these connections.

Once complete, the cover is finally fitted onto the locating pins and the 6 off M6 x 30 T30 security fixings will need to be refitted after applying some anti seize compound to the threads, for location see Figure 13 - Cover Removal in section 4.5.2. A T30 security bit and torque wrench will be required to torque the fixings to 4.5 Nm.

Once the electrical connection is completed, **DO NOT** switch on the power to the Potenza DGI or Velox / Ultra Rapid EVC. Ensure that any isolation devices are **OFF** and locked to prevent unauthorised switch on.

Ensure you download and complete the installation checklist, which can be found in Appendix B – Installation Checklist Document. This will conclude the installation process.

4.6.2. Connection of cables to HMI Screen, Payment device and PE stud

When removing or refitting the front cover there is a need to remove the HMI, the Payment Device and the PE Stud, they must be reconnected, please see below images showing how to reconnect:



Figure 18 - HMI Connections

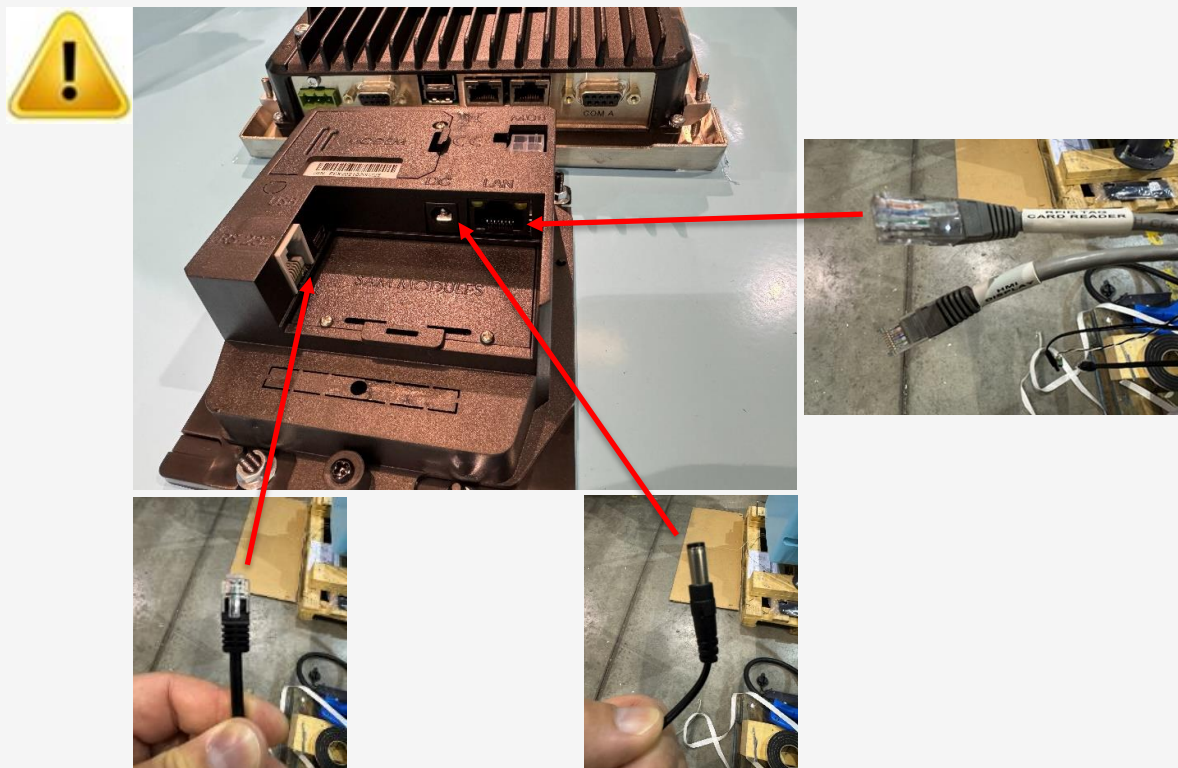

Figure 19 - Payment Device Connections

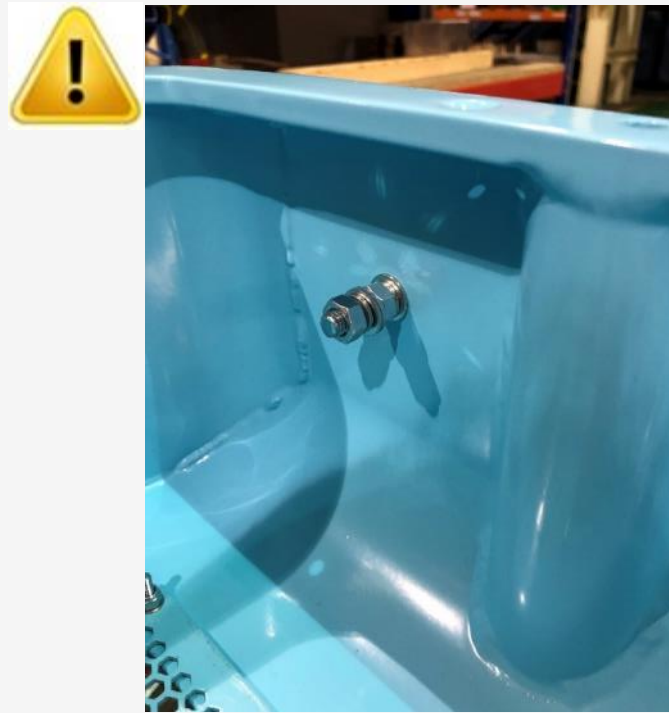

Figure 20 - PE Connection

Please note: The PE cable should be attached to the stud inside the front cover as shown. The fixings will be in place, remove the M8 nut, spring washer and flat washer, fit the cable then replace the nut and washers. Tighten to 6.5 Nm.



5. Commissioning

Please note: Commissioning can only take place once the installation stage has been completed correctly and in full.

The commissioning of the Velox / Ultra Rapid EVC is a detailed and complex process which must only be undertaken by either Turbo Power Systems or an approved / trained person.

To arrange commissioning, or in the event that your Velox / EVC needs to be relocated or decommissioned, please contact your TPS Product Support team. Details are provided in section 1.1.

6. Velox / Ultra Rapid EVC Operation

The EVC's HMI will take the USER through a step-by-step process of charging / discharging an EV. The sequence and screen layout may differ depending on the configuration of the EVC supplied. The basic sequence with example screen layouts are as follows:

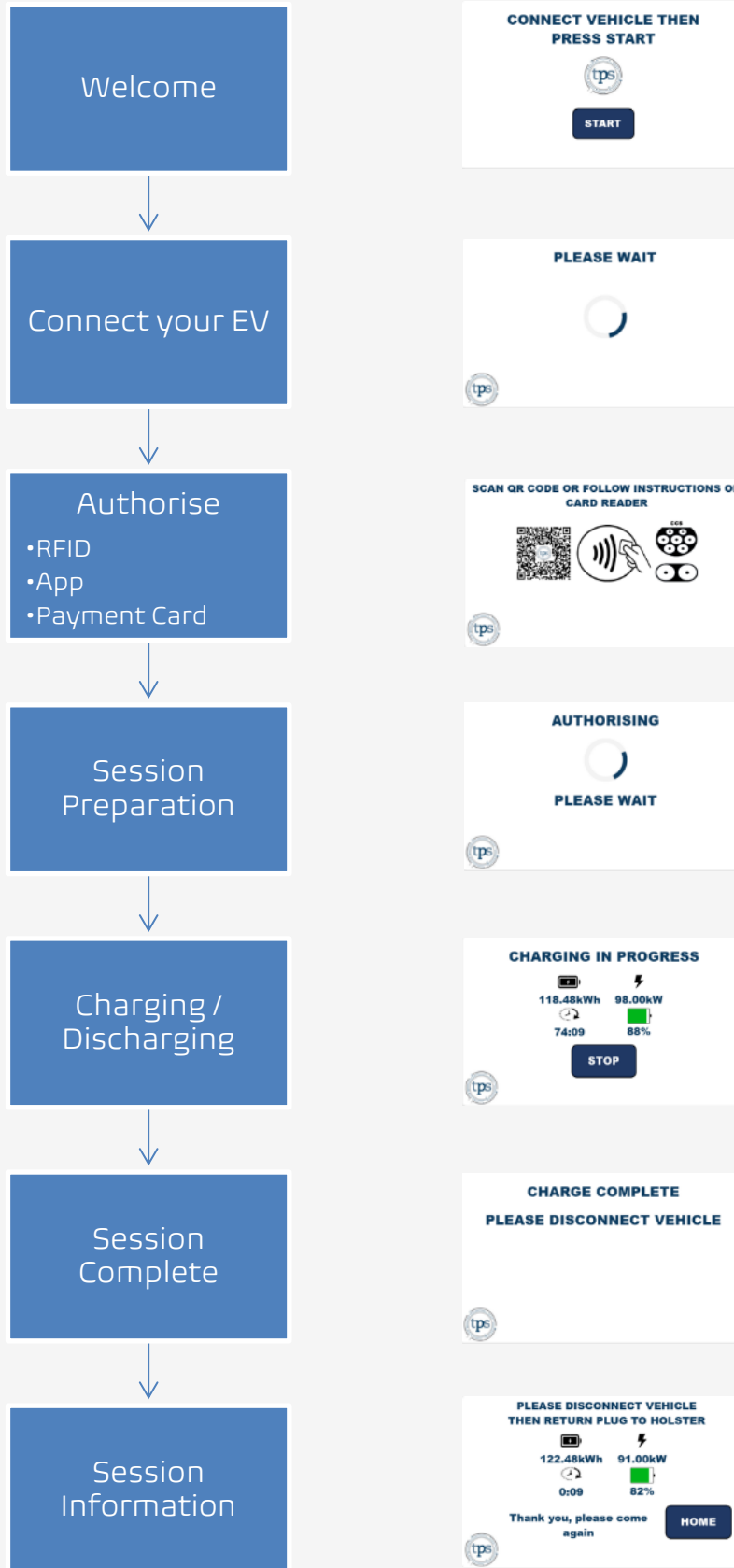

If there is an issue, and the EVC is offline, the following screen will be shown.
If this is the case, contact the Back Office or TPS Customer Support team for assistance.



7. Preventative Maintenance and Inspection Information

PLEASE NOTE: the Velox i Ultra Rapid EVC contains no USER serviceable components. All repairs and maintenance can only be carried out by either Turbo Power Systems or an approved / trained representative. Please refer to customer contractual agreements for specific details.

However, there are a number of preventative maintenance and inspection activities which can be carried out by the USER.

TPS recommends that all preventative maintenance and inspection activities should be recorded with a date using the form provided in Appendix C – Maintenance & Inspection Record

The schedule of activities and frequency is shown below. Please use this for reference before completing the record form in Appendix C – Maintenance & Inspection Record.

Ref No.	Equipment Part No. / Description	Interval (Months)	Type of Inspection
7.1	Cables, Connectors & Holsters	1	Visual / replace if damaged
7.2	Cleaning the Exterior of the Velox i Ultra Rapid EVC	3	Visual and clean
7.3	Air Ducts	3	Visual / clean / replace as req'd
7.4	Enclosure and Hatches	6	Visual
7.5	LEDs	12	Visual
7.6	HMI	12	Visual and Test
7.7	Payment device / RFID	12	Visual and Test
7.8	Isolation Switches	12	Visual and Test

7.1. Cables, Connectors & Holsters

Locate the connectors at the sides of the Velox / Ultra Rapid EVC.

Check that the cables are still located correctly within the glands through which they enter the EVC frame.

Check all connectors for any damage.

Check all cables for signs of damage and or wear.

Check holsters for damage and or wear.



If there are any visible defects, corrosion, or damage; this should be reported to the OWNER of the EVC.

7.2. Cleaning the Exterior of the Velox / Ultra Rapid EVC



When cleaning the exterior, do not use high pressure water jets (pressure washer or steam cleaner) as there is a risk water can enter into the interior and cause serious damage to internal components and / or potentially electrocution to persons.

1. Rinse with low pressure tap water to remove rough or loose dirt.
2. Apply a mild detergent-based cleaning solution if required and let it soak.
3. Manually remove dirt with a non-abrasive tool such as a sponge or brush.
4. Rinse with low pressure tap water.

If there are any visible defects, corrosion, or damage; this should be reported to the OWNER of the EVC.

7.3. Air Ducts and Vents

Locate all ducts using the image below as a guide. Ensure that all vents are free from debris such as leaves or rubbish. Pay particular attention to the vents underneath the EVC front and rear covers.

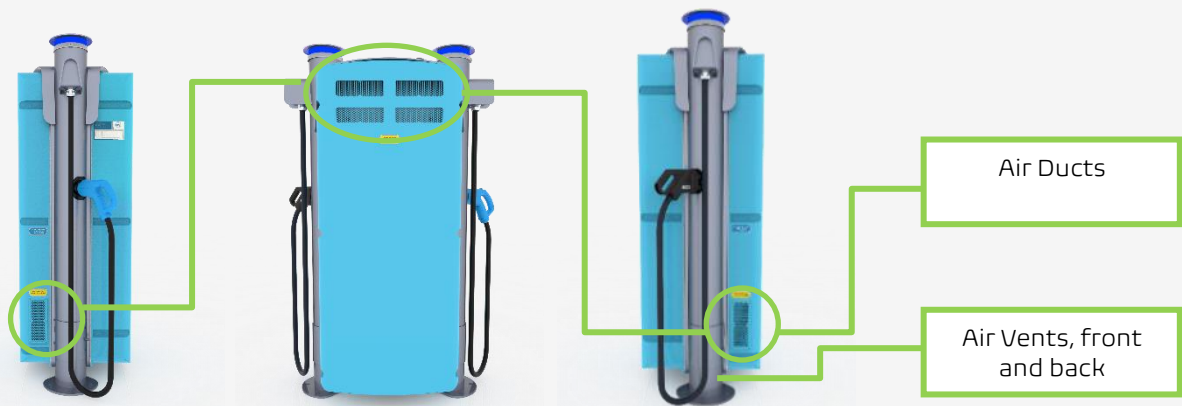

7.4. Enclosure and Hatches

Locate the Maintenance Hatch on the LH frame leg. Remove the 4 off anti-tamper screws with a Security Torx T30 screwdriver. Inspect the cover gasket, replace if damaged (TPS part no. 409105). Refit the cover applying anti seize compound to the threads of the 4 screws.

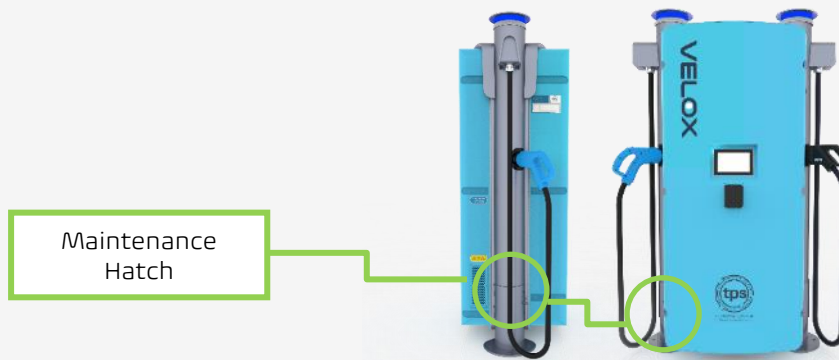

7.5. LEDs

Locate LED's (if fitted). Make sure they are clean and damage free.

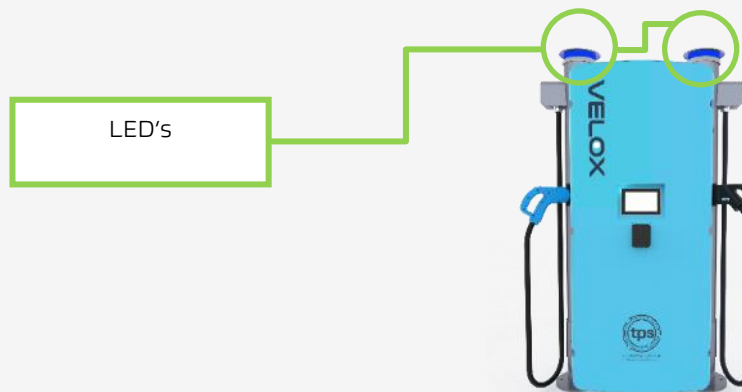

7.6. HMI

Locate HMI. Make sure it is clean and damage free.

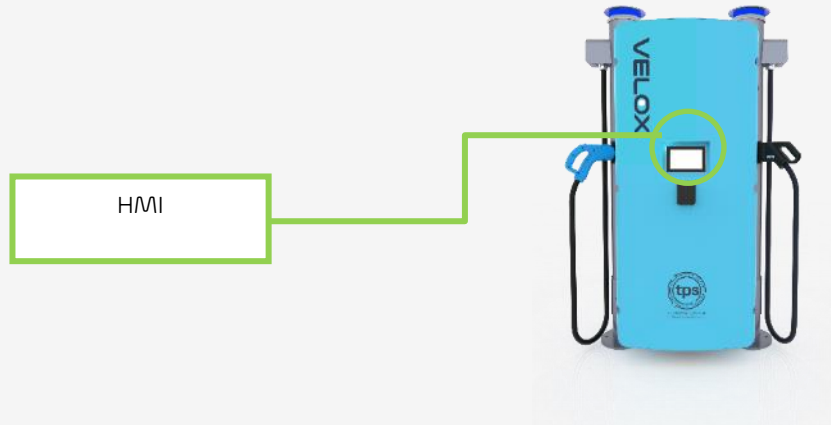

7.7. Payment device / RFID

Locate Payment device / RFID (if fitted). Make sure it is clean and damage free.



7.8. Isolation Switches

Locate Isolation Switches Inside the Maintenance Hatch, see section 7.4 for details on hatch maintenance.

At least once every 12 months perform a full power down cycle of the EVC. Please refer to section 8.2 for instructions on how to carry out this operation.

Please observe the following when the EVC powers up:

- The LEDs will turn RED when the EVC power is first switched on.
- The LEDs will turn GREEN when the EVC is ready to operate.
- The LEDs will only turn BLUE when the EVC is connected to a vehicle and operating.
- The HMI screen will be blank when the EVC power is first switched on.
- The HMI screen will display once the EVC is ready to operate and the vehicle controller is ready.
- The payment device(s), if fitted, can take up to 10 mins to reset from power on.

8. Trouble shooting

The table below shows a list of faults that may arise and actions that will help with troubleshooting. If they do not, please contact TPS for support. Refer to section 1.1 for details of how to do this.

8.1. Fault codes and actions

Ref. #	Fault	Action
1	RED Fault LED	Attempt software reset if possible (OCPD)
2	RED Fault LED	Hard reset – Full Power Cycle (Allow 2 mins to fully reboot)
3	RED Fault LED	If issue cannot be resolved by 1 & 2, Contact TPS, see section 1.1 for details
4	HMI screen is black and does not light up	Recycle input power supply, contact back office
5	Unable to lock the charging connector	Connect EVC cable to EV correctly
6	Unable to lock the charging connector	You are not authorised to use the EVC, contact back office
7	Unable to unlock the charging connector	Wait 5 mins, restart charge session
8	Issue with EV	Report to back office and follow guidance
9	HMI displays 'out of order'	Report to back office and follow guidance

8.2. Performing a Hard Reset or Full Power Cycle

The 800 VDC bus and AC Maintenance Hatch is positioned on the left side (when viewed from the front of the unit) of the support frame and contains both DC and AC isolators. Both have padlock positions to ensure the EVC is isolated whilst maintenance is being carried out. The hatch is secured with 4 off anti-tamper screws which can be removed using a Security Torx T30 screwdriver.

- Remove the tamper proof screws on the Maintenance Hatch.
- Open the Maintenance Hatch.
- Turn OFF the SW1(DC) and SW2(AC) switches (OFF positions clearly labelled).
- Wait for a minimum of 2 mins.
- Turn ON the SW1(DC) and SW2(AC) switches (ON positions clearly labelled).
- Allow a minimum of 2 mins for the control system to reboot. If payment options have been specified, there may be a delay of 5- 10 mins while they reboot and are ready for use. See 7.8.
- Replace the Maintenance Hatch and tamper proof screws after applying anti seize compound to the threads.

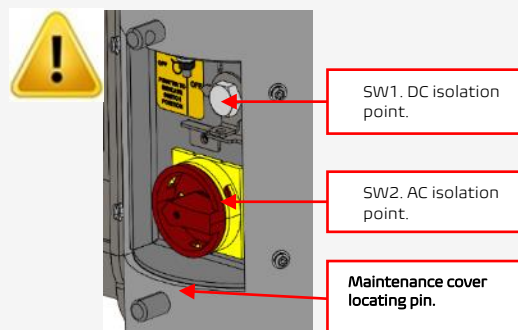

Figure 21 - Hard Reset of Full Power Cycle

9. End of Life Disposal of the Velox / Ultra Rapid EVC or component parts



Incorrect waste handling has a negative impact on the environment and human health due to risk of exposure to hazardous substances. By following appropriate guidelines when dealing with disposal of the EVC or its components you will contribute to reuse and recycling of materials and protection of the environment.

- Obey the local laws and rules when you discard parts, packaging material or the EVC as a whole.
- Discard electrical and electronic equipment separately in compliance with the WEEE - 2012/19/EU Directive on waste of electrical and electronic equipment.
- As the symbol of the crossed out wheeled-bin on your EVC indicates, do not mix or dispose the EVC with your household or commercial waste, at the end of use. Instead, hand the EVC over to your local community waste collection point for recycling.

For more information, contact the Government Waste-Disposal department in your country.

10. Document History

Revision number	Revision Date	Summary of Changes	Changed By
1	30/05/2024	New document	A Lister



11. Appendix A – Velox / Ultra Rapid EVC – Outline Drawing

Indicative information only. Dimensions may be subject to change. Latest revision can be found here: [801325-Outline](#)





12. Appendix B – Installation Checklist Document

Link to latest version:- [Checklist items](#)

Checklist items	Completed?
Do you have all necessary tools as set out in section 4.1?	
Have you unpacked the Velox / Ultra Rapid EVC as set out in section 4.3?	
Have you lifted the Velox / Ultra Rapid EVC in location as set out in section 4.4?	
Have you mechanically installed the Velox / Ultra Rapid EVC as set out in section 4.2?	
Have you electrically installed the Velox / Ultra Rapid EVC as set out in section 4.5?	

Completed By	Date

13. Appendix C – Maintenance & Inspection Record

Link to latest version:- [Maintenance & Inspection Record](#)

Ref. #	Inspection Details List - Description	Inspection Requirement	Completed By	Date
7.1	Cables, Connectors & Holsters	All operating correctly		
7.2	Cleaning the Exterior of the Velox / Ultra Rapid EVC	Clean and Functional		
7.3	Air Ducts	All operating correctly		
7.4	Enclosure and Hatches	All operating correctly		
7.5	LEDs	All operating correctly		
7.6	HMI	All operating correctly		
7.7	Payment device / RFID	All operating correctly		
7.8	Isolation Switches	All operating correctly		



14. Appendix D – Packing

Link to the latest version:- [801325 120kW 920V EV Charger Packing Instruction](#)

15. Appendix E – Velox / Ultra Rapid EVC – Foundation Proposal

Indicative information only. Dimensions may be subject to change. Latest information can be found on the manufacturer’s website, link below:

<https://nal.ltd.uk/ev-charging/products/universal-ev-foundation/high-power-foundation>

PRODUCT SPECIFICATION FOR RETENTION SOCKET WITH STACKABOX ACCESS CHAMBER

- RETENTION SOCKET TOPS MUST BE CONSTRUCTED FROM CAST STEEL TO BS2400 OR DUCTILE IRON TO BS2789 500.7
- RETENTION SOCKETS MUST BE CAPABLE OF WITHSTANDING HIGH SPEED VEHICLE IMPACT FROM ANY DIRECTION TO REMAIN INTACT AND TO REMAIN FULLY FUNCTIONAL AND BE ABLE TO WITHSTAND IMPACT WITHOUT ANY STRUCTURAL SURROUND TO THE TOP BRIM OF THE UNIT. A VALID IMPACT TEST MUST RESULT IN A POST DEFORMATION GREATER THAN 30 PERCENT. ALL SOCKETS MUST BE IMPACT TESTED. TEST DATA AND INDEPENDENT FOUNDATION
- POSTS MUST BE AVAILABLE TO SUPPORT CLIMBING FOR SOCKETS AND
- POSTS MUST BE POSITIVELY SECURED INTO THE RETENTION SOCKETS AND BE ABLE TO WITHSTAND A TURNING MOMENT OF 3.4kNm THROUGH A LOAD OF 250kg @ 1.5METRE FROM THE TOP OF THE SOCKET TO THE POST. THE POSTS MUST NOT DAMAGE THE COATING OR GALVANISED SURFACE OF THE POST.
- ALL FININGS WHICH SECURE POSTS IN PLACE MUST BE HOUSED BELOW GROUND
- RETENTION SOCKETS MUST BE TESTED TO EN124 - B123 (12.5 TONNE) LOADING.
- PEDESTAL PLUGS MUST BE ABLE TO BE STORED WITHIN THE SOCKET TO ENABLE RAPID DEPLOYMENT IN THE CASE OF AN EMERGENCY
- LOADING COMPONENTS MUST BE SERVICEABLE ON SITE WITHOUT REMOVING THE SOCKET
- THE RETENTION SOCKET MUST BE CAPABLE OF ACCOMMODATING GRADED SURFACES IN PAVED AREA SUCH AS THOSE AT PEDESTRIAN CROSSING.
- SOCKET PEDIESTAL PLUGS MUST BE SERVICEABLE ON SITE WITHOUT REMOVING THE SOCKET
- THE RETENTION SOCKETS MUST BE ABLE TO SUPPORT ROAD & BRANLIT SUPPLIES.
- FOR PEDESTAL DESIGN (SOLUTIONS FOR ALL SIZES AND TYPES OF RETENTION SOCKETS IN THE EVENT OF AN IMPACT TO A RETENTION SOCKET THAT HAS BEEN INSTALLED ACCORDING TO THE MANUFACTURER'S INSTRUCTIONS, THE RETENTION SOCKET MUST BE CAPABLE OF WITHSTANDING THE FULL WEIGHT OF THE RETENTION SOCKET AND BE RESPONSIBLE FOR REPLACEMENT OF THE RETENTION SOCKET AND ALL ASSOCIATED RE-INSTALLMENT COSTS.
- RETENTION SOCKETS WILL HAVE THE ABILITY TO ACCEPT ADAPTER PLATES FOR ALL EV CHARGERS.
- RETENTION SOCKETS WILL BE POSITIVELY RIGID TO THE CHAMBER BELOW
- ACCESS CHAMBERS MUST BE MANUFACTURED FROM HIGH GRADE THERMOSET MATERIAL AND BE COMPLETELY RECYCLABLE AT THE END OF LIFE.
- ACCESS CHAMBERS SHALL BE A THIN-WALL DESIGN AND ASSEMBLED FROM STACKABLE ACCESS CHAMBERS MUST BE TESTED TO WITHSTAND A MINIMUM VERTICAL LOAD OF 90 TONNES WITHOUT THE USE OF CONCRETE SURROUND FOR SUPPORT. ONLY THE RETENTION SOCKET WILL REQUIRE CONCRETE SURROUND FOR SUPPORT.
- THE RETENTION SOCKET SHALL BE 150mm DEEPER IN WIDTH THAN 150mm POSITIONED AT THE BOTTOM OF EACH SECTION, TO ALLOW FULL SECTION DEPTH COMPACTION.
- EXTERNAL WALLS SHALL BE FREE FROM MOLDING VIDS THAT WILL NEGATIVELY IMPACT THE STRENGTH OF THE SOCKET WHICH SHOULD BE IN ACCORDANCE WITH THE NEW ACCESS CHAMBERS MUST NOT BE JOINED IN THE CORNER OR REQUIRE MECHANICAL JOINTS TO ACHIEVE STRENGTH.
- ACCESS CHAMBER SECTIONS MUST HAVE THE ABILITY TO BE ADJUSTED IN HEIGHT DURING INSTALLATION TO ACCOMMODATE VARIATIONS IN CHAMBER HEIGHT WITHOUT LOSS OF STRENGTH TO ALLOW FOR TRANSITIONAL GRADIENT INSTALLATIONS.
- ALL RETENTION SOCKETS WITH ACCESS CHAMBER MUST BE PROVIDED TO THE ABOVE SPECIFICATION BY NAL LTD OR ANY EQUALLY APPROVED MANUFACTURER.

COMPANY: NAL LTD, WINDYBUSH DRIVE, WINDYBUSH, THE COXES, LEICESTERShire, LE15 7EE	PROJECT: EV HIGH POWER CHARGE (HPC) FOUNDATION - VELOX RANGE EV CHARGER	CLIENT: S&B BANK
DATE: 08/02/2023	REVISION: 1 of 1	SCALE: 1:20
DRAWN BY: BAU	CHECKED BY: BAU	DATE: 15/02/2023
DESIGNED BY: BAU	APPROVED BY: CR	DATE: 08/02/2023
PROJECT NO.: 9000-1027	ISSUE NO.: A	DATE: 08/02/2023
PROJECT NAME: EV HIGH POWER CHARGE (HPC) FOUNDATION - VELOX RANGE EV CHARGER	ISSUE DESCRIPTION: FIRST ISSUE	DATE: 08/02/2023
PROJECT NO.: 9000-1027	ISSUE NO.: B	DATE: 15/02/2023
PROJECT NAME: EV HIGH POWER CHARGE (HPC) FOUNDATION - VELOX RANGE EV CHARGER	ISSUE DESCRIPTION: ADAPTER PLATE PART CODE ADDED	DATE: 15/02/2023

16. Appendix F – Velox / Ultra Rapid EVC Reinforced Concrete Base

Neil Henderson Consulting Engineers Ltd

Consulting Civil & Structural Engineers

Telephone No. 0775 9257684

email: info@nhce.co.uk

Design Requirements & Performance Specification TPS Document Number: 325-067

500V and 920V EV Charger Reinforced Concrete Base

CLIENT: Turbo Power Systems

DATE: April 2023 (Revised November 23)

Director: Neil Henderson BEng (Hons) CEng MICE PG Cert
Company No. 12821112 Registered in England & Wales

PERFORMANCE SPECIFICATION & DESIGN REQUIREMENTS

1. Site wind loads should be derived from BS 6399 – loadings for buildings, part 2 - wind loading and consider the code requirements such as location and topography depending on the methodology adopted.
2. Concrete for the base should be designed in accordance with British Standard BS 8110 – part 1 / BS EN 1992-1-1 Eurocode 2 – design of concrete structures.
3. Durability exposure conditions should be taken as SEVERE or worse with a minimum requirement of 40mm nominal cover to all reinforcement, maximum free water / cement ratio 0.55 and the minimum cement content should be 325 kg/m³ with the lowest design grade of concrete to be C40.
4. The specification and design requirements should be read in conjunction with TPS drawing No. 800325-OUTLINE, Latest Revision for 500V EV Chargers & 801325-OUTLINE, Latest Revision for 920V EV Chargers. All information should be checked to ensure these are the latest releases; all dimensions should be checked on site against the drawings and specification.
5. The above specification notes are intended as a general guide for minimum requirements for estimating purposes and designing the works but may be varied by the design Engineer to suit local conditions and preference.
6. The minimum recommended fixing bolt should be a M16 Rawplug R-HPTII-ZF "D" zinc flake through-bolt (product code: R-HPTIIZFD16140/20) with large washer or equal/or above equivalent. Design pull-out and shear loads should be determined to suit local site conditions but as a guide unfactored tensile and shear loads for each bolt should be 7kN and 2kN respectively. The weight of the charger unit is as provided by TPS.
7. The client is responsible for understanding local site conditions and specifying any additional protection measures for the apparatus that they deem to be necessary for the safe operation of their installation site.
8. The client shall be responsible for appointing a principal designer and a principal contractor (if more than one contractor is involved) who is competent to oversee the proposed design works as required and outlined in the overall design details and specification and who will undertake the legal duties under CDM 2015 on behalf of the client.

Doc. ref. 500V & 920V-EV Base / Issue version 0.2 – 22.11.2023

Author: N. Henderson

Director: Neil Henderson BEng (Hons) CEng MICE PG Cert
Company No. 12821112 Registered in England & Wales



This page is intentionally left blank.